



# DINGLI

*Exceed · New Height*



Aerial work platform operation



Rust removal operation



Spray painting operation



**BM32M**

ZHEJIANG DINGLI MACHINERY CO., LTD.

ADD:188 Qihang Road, Leidian Town, Deqing, Zhejiang, P.R.C

P.C:313219

Tel:+86-572-8681688

E-Mail:export@cndingli.com

Https://www.cndingli.com

As the technology is constantly updated, technical parameters are subject to change without notice. This brochure is for reference only. The copyright is owned by Zhejiang Dingli. No content may be copied or plagiarized for any purpose without written permission. October 2024 edition

**BM32M**

**Aerial work platform operation**

Max. working height <b>A</b>	32.40m - 106ft 4in
Max. platform height <b>B</b>	30.40m - 99ft 9in
Max. working scope	10.15m - 33ft 4in
Platform dimensions(L×W)	1.24×0.74m - 4ft 1in×2ft 5in
Working state overall dimensions(L×W×H)	
- Retracted	6.29×4.00×13.40m 20ft 8in×13ft 1in×44ft
- Extended	12.90×4.00×24.16m 42ft 4in×13ft 1in×79ft 3in
Max. load capacity	
Max. occupants	1
Time required for amplitude of the horizontal boom (1person+equipment)	454kg1001lb
- Fully extended(Up/Down)	64s/52s
- Fully retracted(Up/Down)	45s/43s
Horizontal boom full movement time (Extension/Retraction)	60s/52s
Time required for mast(Lift/Descend)	90s/90s
Time required for spray painting rack(Lift/Descend)	70s/70s

**Rust removal operation**

Max. working height <b>C</b>	22.20m - 72ft 10in
Max. working scope <b>D</b>	10.10m - 33ft 2in
Working state overall dimensions(L×W×H)	
- Retracted	6.23×4.00×13.40m 20ft 5in×13ft 1in×44ft
- Extended	12.83×4.00×23.58m 42ft 1in×13ft 1in×77ft 4in
Rust removal motor displacement	10cc
Rust removal motor speed	1400~1600rpm
Time required for mast(Lift/Descend)	90s/90s
Time required for spray painting rack(Lift/Descend)	70s/70s

**Spray painting operation**

Max. working height <b>E</b>	27.00m - 88ft 7in
Max. working scope <b>F</b>	10.87m - 35ft 8in
Working state overall dimensions(L×W×H)	
- Retracted	6.98×4.00×13.40m 22ft 11in×13ft 1in×44ft
- Extended	13.59×4.00×26.40m 44ft 7in×13ft 1in×86ft 7in
Applicable worksite	Ship side spraying operation
Spray mode	Semi-automatic
Visual positioning	Point laser positioning guide to ensure that the spray gun is always perpendicular to the surface to be sprayed, and maintain a certain distance
Control method	Industrial remote control operation
Spray area(Single Application)	3800×1260mm12ft 6in×4ft 2in
Working height	1~27m - 3ft 3in~88ft 7in
Spray painting robot running speed	0.1~1m/s - 4in~3ft 3in/s
Spray painting robot(L×W×H)	1600×1500×5200mm 5ft 3in×4ft 11in×17ft 1in
Horizontal boom full movement time (Extension/Retraction)	60s/52s
Time required for mast(Lift/Descend)	90s/90s
Time required for spray painting rack(Lift/Descend)	70s/70s

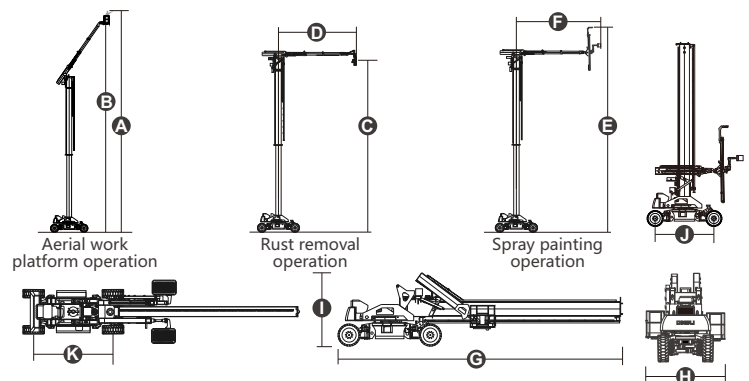

**Standardized Parameters**

Platform rotation	-90~90°
Main boom amplitude angle	-30~55°
Turntable rotation	350°Discontinuity
Dock passing doorway(W×H)	6.00×4.50m 19ft 8in×14ft 9in
Transport size for flatbed truck(L <b>G</b> ×W <b>H</b> ×H <b>I</b> )	15.03×2.43×3.86m 49ft 4in×8ft×12ft 8in
Turntable tail swing(Axles extended/Retracted)	0.34m/1.13m 1ft 1in/3ft 8in
Min. dock passing slope	10%
Ground clearance	0.40m - 1ft 4in
Wheelbase(Axles extended <b>J</b> /Retracted <b>K</b> )	4.28m/4.35m 14ft/14ft 3in
Max. working slope	3°
Tire and Wheels	Foam filled tire and wheel 445/50D710
Min. turning radius(Inside/Outside)	
- Axles extended	2.99m/5.41m 9ft 10in/17ft 9in
- Axles retracted	8.27m/10.85m 27ft 2in/35ft 7in

Steering mode	4×4×4
Falling protector	
- Model	SAJ40-0.5
- Speed	0.35m/s - 1ft 2in/s
- Brakeload	40kN
Travel speed(Stowed/Raised)	6.0km/h / 1.1km/h 3.73mph / 0.68mph
Gradeability(Forward/Backward)	40% / 10%
Overall weight	23500kg - 51809lb
Diesel engine	Deutz TD2.9 L4/55.4kW
Generator	12kW/220V/50Hz
Air compressor	12L-600W
Emergency power system	12V
Hydraulic tank	250L - 66gal
Diesel tank	135L - 35gal