

SPECIFICATIES

Afmetingen	Metrisch	Imperial
Max. werkhoogte	18.26m	59ft 10in
Max. platformhoogte	16.26m	53ft 4in
Max. werkbereik (+ 0,6 m.)	11.32m	37ft 2in
Max. platformbereik	10.72m	35ft 2in
Vlakbed transportafmetingen (l x b x h)	6.48m×2.44m×2.68m	21ft 3in×8ft×8ft 9in
Standaard containertransport	Alles van toepassing	Alles van toepassing
Platformgrootte (lengte x breedte)	1.83m×0.79m	6ft×2ft 7in
Draaitafel staartvleugel	1.18m	3ft 10in
Bodemvrijheid A	0.31m	1ft
Wielbasis B	2.40m	7ft 10in
Draaicirkel (binnen/buiten)	3m/4.73m	9ft 10in/15ft 6in
Banden	315/55D20	315/55D20

Prestatie		
Veilige werkbelasting	320kg	705lb
Max. aantal inzittenden	2	2
Gradatie	40%	40%
Verplaatsnelheid (ingeklapt)	6.0km/h	3.7mph
Verplaatsnelheid (uitgevouwen)	1.1km/h	0.7mph
Max. werkhelling	X-5°/Y-5°	X-5°/Y-5°
Koepelrotatie	360° continue	360° continue
Platformrotatie	180°	180°
Giekbeweging	132°	132°

Gewicht		
Algeheel gewicht (loodaccu)	7750kg	17085lb
Algeheel gewicht (lithiumaccu)	7300kg	16094lb

Vermogen		
Dieselmotor	Kubota Z482/9.8kW	Kubota Z482/9.8kW
loodaccu	48V/300Ah	48V/300Ah
lithiumaccu	48V/280Ah	48V/280Ah
Oplader	48VDC/60A	48VDC/60A
Aandrijfmotor	34VAC/9kW	34VAC/9kW
Hefmotor	34VAC/13kW	34VAC/13kW
Dieseltank	90L	23gal
Hydraulische tank	145L	38gal

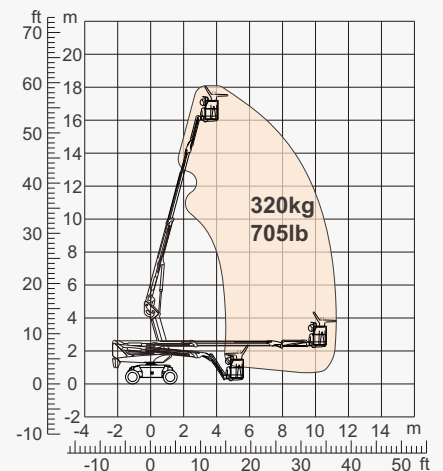

Bewegingsbereik

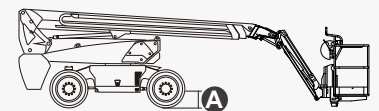
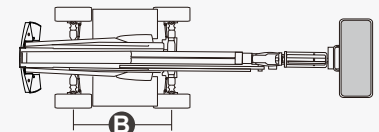

FUNCTIES

Standaard onderdelen

- 1.50m (4ft 11in) Jib
- Oscillerende as voor
- Sturing op twee wielen
- Vierwielaandrijving
- Zelfcorrigerend platform
- 180° links en rechts zwaaiend platform
- Proportionele joystickbesturing
- Duimtuimelsturing
- Rijden inschakelen
- Netstroomkabel naar platform
- Kantelalarm
- Afdaalalarm
- Knipperend LED-baken
- Toeter
- Urenmeter
- Integrale geïntegreerde speciale aandrijf-as voor bouwmachines
- 360° continue draaischijfrotatie
- Positieve tractie vierwielaandrijving
- Platformbelading sensorsysteem
- Diagnostisch systeem aan boord
- Uitvoerder anti-extrusie beschermingssysteem
- Zwaar terreinkits
- 12 V DC reservestroom
- Accu 300Ah/48V
- Aandrijfmotor 9 kW 4834 tpm
- Hefmotor 13 kW 1855 tpm



Telescopische giek-BT



werkhoogte -18m



Giekbeweging



Hybride-H



Ruw Terrein-RT

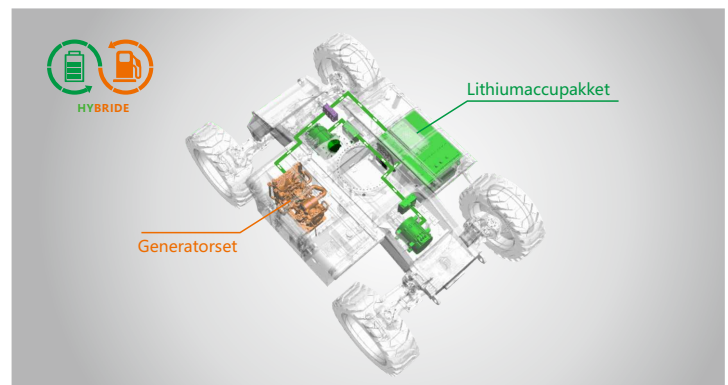

Hybride superlang uithoudingsvermogen van 30 dagen

ZHEJIANG DINGLI MACHINERY CO., LTD.

Address: No.188 Qihang Road, Deqing, Zhejiang P.R.C 313219

Telephone: +86(572)8681688

E-Mail: export@cndingli.com

[Https://en.cndingli.com](https://en.cndingli.com)

Due to continuous technology updates, technical parameters are subject to change without notice. This picture book is for reference only, the actual product shall prevail. The copyright is owned by zhejiang dingli, any content may not be copied for any purpose without written permission.

2025-04