

## SPECIFICATIONS

Size	Metric	British
Max. Working Height	24.20m	79ft 5in
Max. Platform Height	22.20m	72ft 10in
Max. Operating Range(+0.6m)	17.64m	57ft 10in
Max. Platform Range	17.04m	55ft 11in
Flatbed Transport Dimensions (L×W×H)	9.36m×2.50m×2.46m	30ft 8in×8ft 2in×8ft 1in
Standard Container Transport	All Applicable	All Applicable
Platform Size(Length×Width)	2.44m×0.91m	8ft×3ft
Turntable Tailswing	1.21m	4ft
Ground Clearance <b>A</b>	0.28m	11in
Wheelbase <b>B</b>	2.50m	8ft 2in
Turning Radius(Inside/Outside)	3.68m/5.54m	12ft 1in/18ft 2in
Tyres	315/55D20	315/55D20

Performance		
S.W.L	300kg	661lb
Max. Occupants	2	2
Gradeability	40%	40%
Travel Speed(Stowed)	6.0km/h	3.7mph
Travel Speed(Raised)	1.1km/h	0.7mph
Max. Working Slope	X-5°/Y-5°	X-5°/Y-5°
Turret Rotation	360°Continuous	360°Continuous
Platform Rotation	180°	180°
Jib Movement	132°	132°

Weight		
Overall Weight	12000kg	26455lb

Power		
Diesel Engine	Kubota D1105/18.2kW	Kubota D1105/18.2kW
Diesel Tank	115L	30gal
Hydraulic Tank	160L	42gal

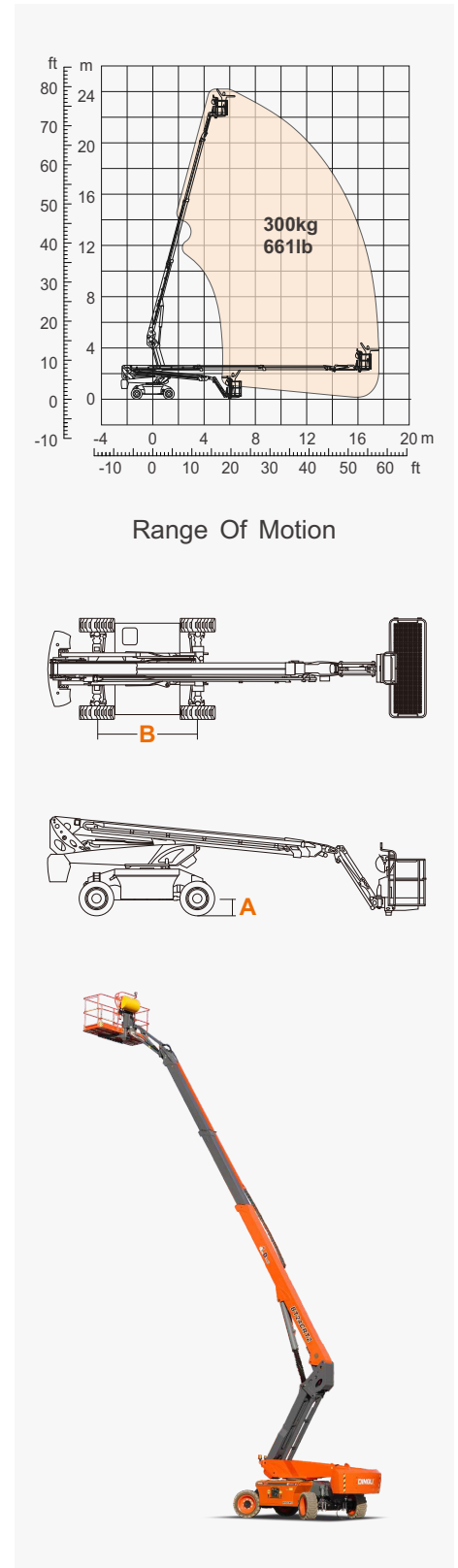

## FEATURES

### Standard Items

- 1.50m (4ft 11in) Jib
- Front Oscillating Axle
- Four-Wheel Steering
- Four-Wheel Drive
- Self-Leveling Platform
- 180° Left And Right Swing Platform
- Proportional Joystick Controls
- Thumb Rocker Steer
- Drive Enable
- Ac Power Cord To Platform
- Tilt Alarm
- Descent Alarm
- Flash
- Horn
- Hour Meter
- Integral Integrated Special Drive Axle  
For Construction Machinery
- 360° Continuous Turntable Rotation
- Positive Traction Four Wheel Drive
- Platform Load Sense System
- Fault Diagnosis System
- Operator Anti-crushing Protection System
- Harsh Environment Kits
- 12V DC Auxiliary Power
- Kubota D1105 18kW 2600rpm Diesel Engine
- Hydraulic Oil Radiator
- Anti-restart Engine Protection
- Anti-reverse Engine Device
- Auto Engine Fault Shutdown



Telescopic  
Boom-BT



Working  
Height-24m



Jib



Diesel Engine



Rough  
Terrain-RT



## ZHEJIANG DINGLI MACHINERY CO., LTD.

Address: No.188 Qihang Road,Deqing,Zhejiang P.R.C 313219

Telephone: +86(572)8681688

E-Mail: [export@cndingli.com](mailto:export@cndingli.com)

[Https://en.cndingli.com](https://en.cndingli.com)

Due to continuous technology updates, technical parameters are subject to change without notice. This picture book is for reference only, the actual product shall prevail. The copyright is owned by zhejiang dingli, any content may not be copied for any purpose without written permission.

2025-03

